

SAMSON

SWT Series

Screw Terminal Type(螺釘型), Standard(標準品)

FEATURES

1. Load life of 2000 hours application of ripple current at +105°C
2. Suit for use in electronic and industrial equipments such as computer, programming control exchanger for power supplies filtering and energy storing.



SPECIFICATIONS

Item	Performance Characteristics	
Operating Temperature Range	-40 to +105°C	-25 to +105°C
Rated Working Voltage Range	10 to 100V	160 to 400V
Nominal Capacitance Range	180 to 680000µF	
Capacitance Tolerance	±20% (120Hz, +20°C)	
Leakage Current	I ≤ 0.02CV or 5(mA) after 5 minutes application of rated working voltage at +20°C, which is smaller	
Low Temperature Characteristics	Impedance ratio max. at 120Hz	
	Working Voltage (V)	10 ~ 100 160 ~ 400
	Z-25°C / Z+20°C	-- 8
Z-40°C / Z+21°C	12 --	
High Temperature Loading	Test conditions	Post test requirements at +20°C
	The following specifications shall be satisfied when the capacitors are restored to 20°C after the rated voltage with the rated ripple current applied for 2000 hours at 105°C	Leakage current : ≤ Initial specified value Cap. change : within ±20% of initial measured value tan δ : ≤ 200% of initial specified value
Shelf Life	At 105°C no voltage applied after 1000hours the capacitors shall meet the following limits Leakage current : ≤ Initial specified value Cap. change : within ±20% of initial measured value tan δ : ≤ 200% of initial specified value	
Others	JIS C - 5141 JIS C - 5102	

SWT Series

Screw Terminal Type(螺釘型), Standard(標準品)

CASE SIZE TABLE

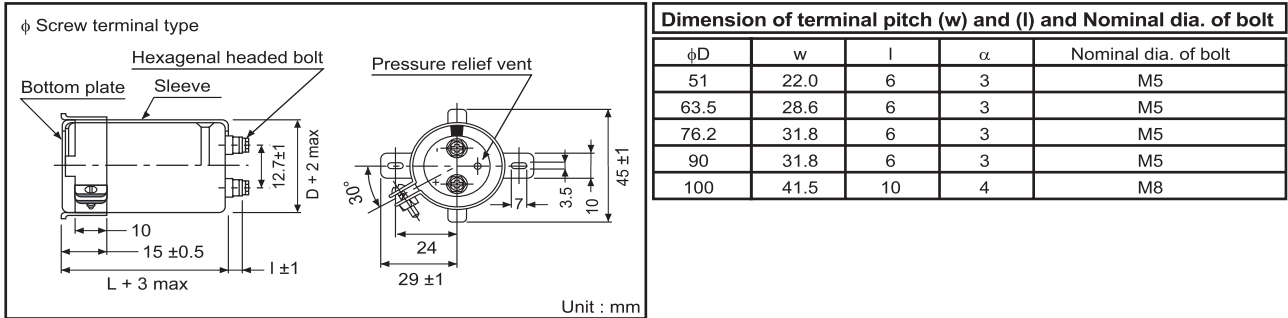
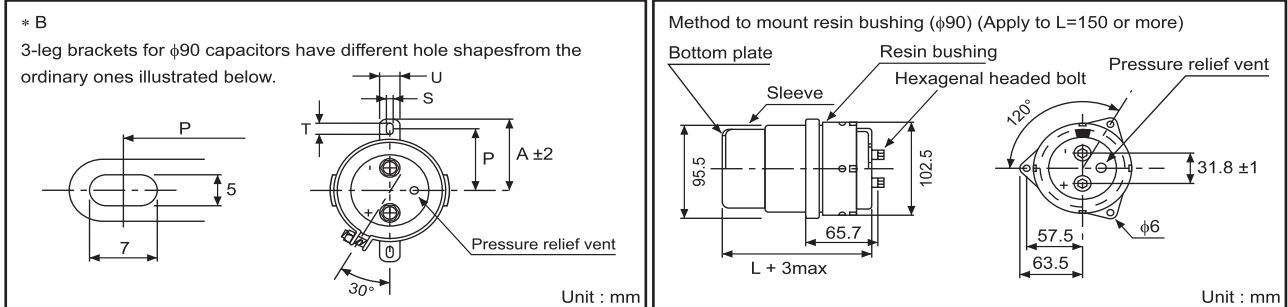
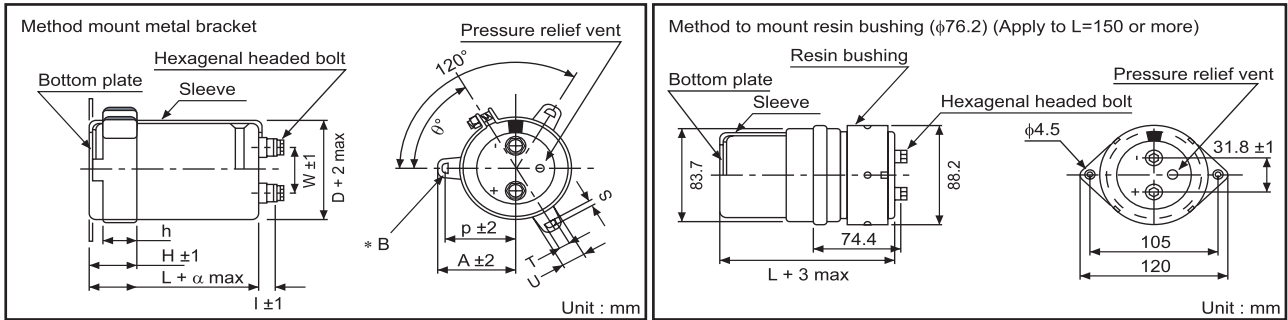

Dimension of mounting bracket										
Voltage (Code)		3 - Leg					2 - Leg			
Symbol	φD	51	63.5	76.2	90	100	51	63.5	76.2	90
P		32.5	38.1	44.5	50.8	56.3	33.2	40.5	46.5	53
A		38.5	43	49.2	58.5	62	40	46.5	53	59
T		7.5	8.0	7.0	8.0	8.0	6.0	7.0	6.0	6.0
S		5.0	5.0	5.0	5.0	5.0	4.5	4.5	4.5	4.5
U		12	14	14	18	16	14	14	14	14
θ°		60	60	60	60	60	30	30	30	30
H		20	25	30	35	36	25	35	35	35
h		15	20	24	25	30	15	20	20	20

RIPPLE CURRENT MULTIPLIER									
Frequency Coefficient									
Rated Voltage(V)	Size(mm)	Freq.(Hz)	50	120	300	1k	10k	50k	
10 to 50	φ 35 to φ 90		0.95	1	1.03	1.05	1.09	1.12	
	φ 35		0.9	1	1.06	1.1	1.18	1.22	
63 & 80	φ 51 to φ 90		0.95	1	1.03	1.05	1.09	1.12	
	φ 35		0.82	1	1.12	1.22	1.3	1.33	
100	φ 51		0.9	1	1.06	1.1	1.18	1.22	
	φ 63.5 to φ 90		0.95	1	1.03	1.05	1.09	1.12	
160 to 250	φ 35		0.8	1	1.19	1.34	1.46	1.52	
	φ 51 & φ 63.5		0.81	1	1.14	1.26	1.36	1.41	
315 to 400	φ 76.2 & φ 90		0.82	1	1.12	1.22	1.3	1.33	
	φ 35 to φ 90		0.8	1	1.19	1.34	1.46	1.52	

SAMSON

SWT Series

Screw Terminal Type(螺釘型), Standard(標準品)

DIMENSIONS										
Voltage (Code)		10			16V			25V		
SV		13			20			32		
Cap.(μ F)	Code	Case Size	Tan δ	Ripple Current	Case Size	Tan δ	Ripple Current	Case Size	Tan δ	Ripple Current
12000	129							35 x 50	0.35	3.7
15000	159							35 x 50	0.35	4.1
18000	189				35 x 50	0.40	4.2	35 x 60	0.35	4.8
22000	229				35 x 50	0.40	4.7	35 x 60	0.35	5.3
27000	279	35 x 50	0.45	4.9	35 x 60	0.40	5.5	35 x 80	0.35	6.4
33000	339	35 x 50	0.50	5.1	35 x 60	0.45	5.7	35 x 80	0.40	6.7
39000	399	35 x 60	0.50	5.9	35 x 80	0.45	6.8	35 x 100	0.40	7.8
47000	479	35 x 80	0.50	7.1	35 x 80	0.50	7.1	35 x 120	0.40	9.3
56000	569	35 x 80	0.60	7.1	35 x 100	0.50	8.4	51 x 80	0.45	9.7
68000	689	35 x 100	0.60	8.5	35 x 100	0.55	8.8	51 x 100	0.45	11.2
82000	829	35 x 100	0.65	8.9	51 x 80	0.55	10.7	51 x 100	0.50	11.2
100000	10T	35 x 120	0.65	10.7	51 x 80	0.65	10.8	51 x 120	0.50	14.8
120000	12T	51 x 80	0.75	11.0	51 x 100	0.65	13.1	63.5 x 100	0.65	14.9
150000	15T	51 x 100	0.80	13.2	51 x 120	0.70	15.3	63.5 x 120	0.65	17.9
180000	18T	51 x 120	0.80	15.7	51 x 120	0.80	15.7	63.5 x 120	0.80	17.9
220000	22T	51 x 120	0.85	16.8	63.5 x 120	0.85	19.2	76.2 x 120	0.85	21.3
270000	27T	63.5 x 120	1.00	19.6	63.5 x 120	1.00	19.6	76.2 x 120	1.00	21.7
330000	33T	63.5 x 120	1.20	19.7	76.2 x 120	1.30	21.1	76.2 x 140	1.20	23.4
390000	39T	76.2 x 120	1.50	21.3	76.2 x 120	1.50	21.3	90 x 140	1.50	24.9
470000	47T	76.2 x 120	1.80	21.4	76.2 x 140	1.60	24.2			
560000	56T	76.2 x 140	2.00	23.6	90 x 140	2.00	28.1			
680000	68T	90 x 140	2.40	26.0	90 x 140	2.40	28.5			

Maximum Allowable Ripple Current (A rms) at 105°C 120Hz

Case Size ϕ D x L(mm)

Tan δ at 20°C 120Hz

Voltage (Code)		35			50V			63V		
SV		44			63			79		
Cap.(μ F)	Code	Case Size	Tan δ	Ripple Current	Case Size	Tan δ	Ripple Current	Case Size	Tan δ	Ripple Current
2700	278							35 x 50	0.20	2.3
3300	338							35 x 50	0.20	2.5
3900	398				35 x 50	0.20	2.8	35 x 50	0.20	2.8
4700	478				35 x 50	0.20	3.1	35 x 50	0.20	3.1
5600	568				35 x 50	0.20	3.3	35 x 60	0.20	3.5
6800	688				35 x 50	0.25	3.3	35 x 60	0.20	3.9
8200	828	35 x 50	0.30	3.3	35 x 60	0.25	3.8	35 x 80	0.20	4.7
10000	109	35 x 50	0.30	3.6	35 x 80	0.25	4.6	35 x 80	0.25	4.7
12000	129	35 x 60	0.30	4.2	35 x 80	0.25	5.1	35 x 100	0.25	5.5
15000	159	35 x 60	0.30	4.7	35 x 80	0.25	5.7	35 x 120	0.25	6.6
18000	189	35 x 80	0.30	5.7	35 x 100	0.25	6.7	51 x 80	0.25	7.4
22000	229	35 x 80	0.30	6.3	35 x 120	0.25	8.1	51 x 100	0.25	9.0
27000	279	35 x 100	0.30	7.5	51 x 80	0.25	9.1	51 x 120	0.25	10.9
33000	339	35 x 120	0.30	9.0	51 x 100	0.25	11.1	51 x 120	0.25	12.0
39000	399	51 x 80	0.35	9.2	51 x 120	0.25	13.1	63.5 x 100	0.30	12.5
47000	479	51 x 100	0.35	11.2	51 x 120	0.30	13.9	63.5 x 120	0.30	14.9
56000	569	51 x 100	0.40	11.4	63.5 x 100	0.35	13.9	63.5 x 120	0.30	16.3
68000	689	51 x 120	0.40	13.6	63.5 x 120	0.35	16.6	76.2 x 120	0.35	18.4
82000	829	63.5 x 100	0.45	14.8	76.2 x 120	0.40	18.9	76 x 140	0.40	20.0
100000	10T	63.5 x 120	0.45	17.6	76.2 x 120	0.45	19.5	76.2 x 140	0.50	20.0
120000	12T	63.5 x 120	0.55	17.6	76.2 x 120	0.55	19.5	90 x 140	0.60	21.8
150000	15T	76.2 x 120	0.65	19.8	90 x 140	0.60	23.9			
180000	18T	76.2 x 120	0.80	19.8	90 x 140	0.75	23.9			
220000	22T	76.2 x 120	0.80	23.4						
270000	27T	90 x 120	1.00	25.5						

Maximum Allowable Ripple Current (A rms) at 105°C 120Hz

Case Size ϕ D x L(mm)

Tan δ at 20°C 120Hz

SWT Series

Screw Terminal Type(螺釘型), Standard(標準品)

DIMENSIONS										
Voltage (Code)		80V			100V			160V		
SV		100			125			200		
Cap.(μF)	Code	Case Size	Tan δ	Ripple Current	Case Size	Tan δ	Ripple Current	Case Size	Tan δ	Ripple Current
560	567							35 x 50	0.15	1.2
680	687							35 x 50	0.15	1.3
820	827							35 x 50	0.15	1.4
1000	108							35 x 50	0.15	1.6
1200	128							35 x 60	0.15	1.9
1500	158							35 x 60	0.15	2.1
1800	188				35 x 50	0.10	2.7	35 x 80	0.15	2.5
2200	228	35 x 50	0.15	2.4	35 x 50	0.10	3.0	35 x 80	0.15	2.8
2700	278	35 x 50	0.15	2.7	35 x 60	0.10	3.5	35 x 100	0.15	3.3
3300	338	35 x 50	0.15	3.0	35 x 80	0.10	4.2	35 x 120	0.15	3.8
3900	398	35 x 60	0.15	3.4	35 x 80	0.12	4.2	51 x 80	0.20	3.8
4700	478	35 x 60	0.15	3.7	35 x 100	0.12	5.0	51 x 100	0.20	4.6
5600	568	35 x 80	0.15	4.5	35 x 100	0.12	5.4	51 x 100	0.20	5.1
6800	688	35 x 80	0.15	4.9	35 x 120	0.15	5.8	51 x 120	0.20	6.1
8200	828	35 x 100	0.20	5.1	51 x 80	0.15	6.4	63.5 x 100	0.20	7.0
10000	109	35 x 120	0.20	6.1	51 x 100	0.15	7.8	63.5 x 120	0.20	8.4
12000	129	51 x 80	0.20	6.7	51 x 120	0.15	9.3	76.2 x 100	0.20	9.4
15000	159	51 x 100	0.20	8.3	51 x 120	0.15	10.4	76.2 x 120	0.20	11.4
18000	189	51 x 120	0.20	9.9	63.5 x 10	0.20	10.4	76.2 x 140	0.20	13.4
22000	229	51 x 120	0.20	11.0	63.5 x 120	0.20	12.5	90 x 140	0.25	14.5
27000	279	63.5 x 100	0.25	11.4	76.2 x 120	0.25	13.7	90 x 140	0.25	16.0
33000	339	76.2 x 100	0.25	13.9	76.2 x 120	0.25	15.2			
39000	399	76.2 x 100	0.30	13.9	76.2 x 140	0.30	16.1			
47000	479	76.2 x 120	0.30	16.5	90 x 140	0.30	19.3			
56000	569	76.2 x 120	0.30	18.1	90 x 140	0.30	21.1			
68000	689	76.2 x 140	0.35	19.7						
82000	829	90 x 140	0.40	22.1						

Maximum Allowable Ripple Current (A rms) at 105°C 120Hz

Case Size φD x L(mm)

Tan δ at 20°C 120Hz

Voltage (Code)		200V			250V			315V		
SV		250			300			365		
Cap.(μF)	Code	Case Size	Tan δ	Ripple Current	Case Size	Tan δ	Ripple Current	Case Size	Tan δ	Ripple Current
180	187							35 x 50	0.10	0.8
220	227							35 x 50	0.10	0.9
270	277				35 x 50	0.15	0.8	35 x 50	0.10	1.0
330	337	35 x 50	0.15	0.9	35 x 50	0.15	0.9	35 x 50	0.10	1.1
390	397	35 x 50	0.15	1.0	35 x 50	0.15	1.0	35 x 50	0.10	1.2
470	477	35 x 50	0.15	1.1	35 x 50	0.15	1.1	35 x 60	0.10	1.4
560	567	35 x 50	0.15	1.2	35 x 50	0.15	1.2	35 x 60	0.10	1.5
680	687	35 x 50	0.15	1.3	35 x 60	0.15	1.4	35 x 80	0.10	1.7
820	827	35 x 50	0.15	1.4	35 x 80	0.15	1.6	35 x 80	0.15	1.7
1000	108	35 x 60	0.15	1.7	35 x 80	0.20	1.6	35 x 100	0.15	2.0
1200	128	35 x 60	0.15	1.9	35 x 80	0.20	1.8	35 x 120	0.15	2.4
1500	158	35 x 80	0.15	2.3	35 x 100	0.20	2.1	51 x 80	0.15	2.7
1800	188	35 x 80	0.15	2.5	35 x 120	0.20	2.5	51 x 100	0.15	3.3
2200	228	35 x 100	0.15	3.0	51 x 80	0.20	2.9	51 x 120	0.15	4.0
2700	278	35 x 120	0.15	3.6	51 x 100	0.20	3.5	51 x 120	0.15	4.4
3300	338	51 x 80	0.15	4.1	51 x 120	0.20	4.2	63.5 x 100	0.15	5.1
3900	398	51 x 100	0.15	4.9	51 x 120	0.20	4.6	63.5 x 120	0.15	6.0
4700	478	63.5 x 100	0.20	5.3	63.5 x 120	0.20	5.7	76.2 x 100	0.15	6.8
5600	568	63.5 x 100	0.20	5.8	63.5 x 120	0.20	6.3	76.2 x 120	0.15	8.0
6800	688	63.5 x 120	0.20	6.9	76.2 x 120	0.20	7.7	76.2 x 130	0.15	9.2
8200	828	63.5 x 120	0.20	7.6	76.2 x 120	0.20	8.4	90 x 140	0.15	11.4
10000	109	76.2 x 120	0.20	9.3	76.2 x 140	0.20	10.0	90 x 140	0.15	12.6
12000	129	76.2 x 120	0.20	10.2	90 x 140	0.20	11.9			
15000	159	76.2 x 140	0.20	12.2						
18000	189	90 x 140	0.25	13.1						

Maximum Allowable Ripple Current (A rms) at 105°C 120Hz

Case Size φD x L(mm)

Tan δ at 20°C 120Hz

SAMSON

SWT Series

Screw Terminal Type(螺釘型), Standard(標準品)

DIMENSIONS										
Voltage (Code)		350V			400V					
SV		400			450					
Cap.(μ F)	Code	Case Size	Tan δ	Ripple Current	Case Size	Tan δ	Ripple Current			
180	187	35 x 50	0.10	0.8	35 x 50	0.10	0.8			
220	227	35 x 50	0.10	0.9	35 x 50	0.10	0.9			
270	227	35 x 50	0.10	1.0	35 x 50	0.10	1.0			
330	337	35 x 50	0.10	1.1	35 x 60	0.10	1.2			
390	397	35 x 60	0.10	1.3	35 x 60	0.10	1.3			
470	477	35 x 60	0.10	1.4	35 x 80	0.10	1.4			
560	567	35 x 80	0.10	1.6	35 x 80	0.15	1.4			
680	687	35 x 80	0.15	1.6	35 x 100	0.15	1.7			
820	827	35 x 100	0.15	1.8	35 x 120	0.15	2.0			
1,000	108	35 x 120	0.15	2.2	51 x 80	0.15	2.2			
1,200	128	51 x 80	0.15	2.4	51 x 100	0.15	2.7			
1,500	158	51 x 100	0.15	3.0	51 x 120	0.15	3.3			
1,800	188	51 x 120	0.15	3.6						
2,200	228	51 x 120	0.15	4.0	63.5 x 100	0.15	4.2			
2,700	278	63.5 x 100	0.15	4.6						
3,300	338				63.5 x 120	0.15	5.5			
3,900	398	76.2 x 120	0.15	6.7						
4,700	478				76.2 x 130	0.15	7.6			
5,600	568	76.2 x 130	0.15	8.3	90 x 140	0.15	9.4			
6,800	688	76.2 x 140	0.15	9.5	90 x 140	0.15	10.4			
8,200	828	90 x 140	0.15	11.4						

Maximum Allowable Ripple Current (A rms) at 105°C 120Hz

Case Size ϕ D x L(mm)

Tan δ at 20°C 120Hz